

# Pour-in Pan Dock Leveler

# BLUE GIANT®

Get the dock leveler pit that you need  
At a fraction of the time and cost

Available in  
30,000, to 80,000 lb  
(13,636, to 36,364 kg)  
Rated Capacities

## ADVANCED BUILT-IN FEATURES

- A Complete dock leveler installation package**  
Loading docks are fully functional more quickly and at a lower cost.
- B Simple installation preparation**  
Pour a concrete pad to support the dock leveler. No field welding required.
- C Built-in side and rear curb angles**  
No extra hardware needed, expediting installation.
- D Safe, level installation**  
A single pouring of concrete brings the pit to the finished floor height.
- E Nelson studs**  
Superior anchoring compared to traditional methods.
- F Weldment**  
Expertly welded for maximum durability.
- G Conduit holes**  
Added support for hydraulic installations.



Mechanical dock leveler pictured above.

Available for all dock leveler types: mechanical, hydraulic and air powered.

## Save Time and Money

- Only the concrete slab requires forming, resulting in lower cost of materials.
- Less time spent stripping and cleaning the pit, cutting billable man hours by half.
- No field welding required, reducing installation costs by up to one-third.

## Dock Pit to Go

- Blue Giant Pour-In Pans are shipped in assembled form, as an integral part of the dock leveler: no cutting of wood forms or complicated installation steps.
- Side and rear curb angles are built into the panels: no extra kits or hardware needed.
- Each pour-in pan ships with front and rear support members for easier, more efficient installation.
- Available with or without a bottom panel to suit installation requirements.

## Superior Design

- Get the pit formed to the correct size every time.
- Durable steel side and rear panels.
- Nelson stud embedment anchors on the back and sides.
- Tapered design for easy water run-off.
- Painted the same color as the dock leveler (unless specified otherwise).
- Compatible with mechanical, hydraulic, and air-powered dock levelers.

## Options

- Rust-inhibiting primer base
- Primer-based paint (only available in blue)
- Cold spray galvanizing for added resistance to rust and corrosion
- 'J' hooks for front curb angle



# Alternative Installations

## Curb Angle Kits

Blue Giant Curb Angle Kits make proper pit formation easier to accomplish. Manufactured to suit any size pit, curb angles cover exposed edges and protect the pit perimeter. Kits are available in the following configurations, ensuring complete:

- Four-Piece: two top sides, one top rear, and one front bottom piece
- Six-Piece: two top sides, one top rear, and one front bottom piece, plus two vertical drops
- Eight-Piece: two top sides, one top rear, and one front bottom piece, plus two vertical drops and two front face horizontals

A special curb angle kit for dock lifts and scissor lifts is also available.

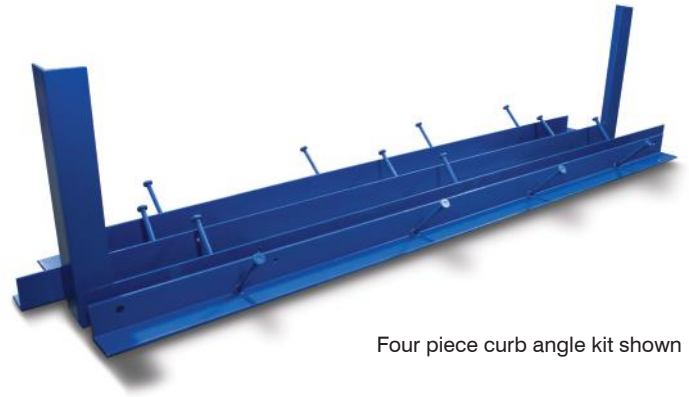

Four piece curb angle kit shown

## Pit Kits



Pit Kit shipped in four pieces – shown field assembled

Blue Giant Pit Kits ensure accurate dimensions by using prefabricated steel panels that are bolted together on site. The result is a true, square pit that's ready to accommodate a dock leveler now or in the future.

- Each pit kit includes three steel panels plus a front curb angle
- Can be used with all dock leveler types
- Less expensive than traditional wood forms

## Paint Color Options

Blue Giant offers our dock levelers in the following paint color options: Standard Blue, Battleship Grey, and Black Gloss.

## Free Standing Frames



Is floor space limited? A Blue Giant free-standing frame assembly allows a dock leveler to be successfully installed outside a building. Free-standing frames are also a solution for issues connected to re-routing gas and water lines.

- Fits all pit-style dock levelers
- Comes with guard rails and pre-installed bumpers
- Can be used with hydraulic, mechanical, and air-powered dock levelers



Standard Blue



Battleship Grey



Black Gloss

**BLUE GIANT**  
BLUE GIANT EQUIPMENT CORPORATION

**Corporate** 85 Heart Lake Road South  
Brampton, ON, Canada L6W 3K2  
t 905.457.3900 f 905.457.2313

**USA** 6350 Burnt Poplar Road  
Greensboro, NC 27409  
[www.BlueGiant.com](http://www.BlueGiant.com)

AUTHORIZED DEALER

Blue Giant offers a full line of dock levelers, dock safety equipment, seals and shelters, accessories, ergonomic and scissor lift equipment and industrial trucks. Concurrent with our continuing product improvement program, specifications are subject to change without notice. Please contact Blue Giant for latest information. Some features illustrated may be optional in certain market areas.